

**FE14  
AND  
FE16  
FIELD EFFECT  
METER**

**S  
E  
N  
C  
O  
R  
E**



**SENCORE SERVICE MANUAL**

426 S. WESTGATE DRIVE, ADDISON, ILLINOIS

## INSTRUCTION MANUAL FOR THE SENCORE FE14 & FE16 FIELD EFFECT METERS

The Sencore FE14 and FE16 Field Effect Meters are a revolutionary new concept in test meters. They take all the advantages of a VTVM and combine them with the advantages of a VOM to make an extremely versatile meter. High input impedance on all AC & DC voltage ranges, peak to peak AC measurements, & DC zero center scales combined with zero warm up time, DC current ranges, and VOM portability makes the Field Effect Meter a truly great instrument. Anyone in the electrical or electronic fields - service technicians, engineers, field engineers, hams, experimenters etc. - will find that the Field Effect Meter is the complete answer to his measuring needs.

No other meter in the FE14 or FE16 class has all of these features in one instrument:

- \* High input impedance on both AC and DC voltage ranges (10 megohms and 15 megohm)
- \* True peak to peak AC ranges.
- \* Zero center ranges for solid state servicing.
- \* DC current ranges for general testing.
- \* Mirrored scale meter for greater accuracy in readings.
- \* Meter protected from overloads.
- \* Circuit protected from accidental application of wrong voltages.
- \* All steel construction for greater durability.
- \* Battery operated for complete portability.

### FE14 SPECIFICATIONS

#### DC VOLTS

Ranges: 0 to 1, 3, 10, 30, 100, 300 and 1000 FULL SCALE  
-.5 to .5, -1.5 to 1.5, -5 to 5, -15 to 15, -50 to 50, -150 to 150  
and -500 to 500 ZERO CENTER SCALE RANGES

Input Resistance: 15 megohms shunted by 14 PF.

Accuracy:  $\pm 2\frac{1}{2}\%$

AC Rejection: 30 to 300 times (30 to 50db).

#### AC VOLTS

Ranges: (Rms)

0 to 1, 3, 10, 30, 100, 300 and 1000 FULL SCALE

Ranges: (Peak to Peak)

0-2.8, 8.4, 28, 84, 280, 840 and 2800 Full Scale, frequency compensated

Input Resistance: 10 megohms shunted by 29 PF.

Frequency Response: Flat: 25HZ to 1MHZ

3db points: 10Hz to 10MHz

Accuracy:  $\pm 4\frac{1}{2}\%$

## OHMMETER

Ranges: 0 to 1000 ohms, 10K, 100K, 10 megohms and 1000 megohms  
Accuracy:  $\pm 2$  degrees ARC

## DC CURRENT MEASUREMENTS

Ranges: 0 - 100 microamps, 1ma, 10ma, 100ma and 1 Ampere  
Accuracy:  $+ 3\%$   
Internal Voltage Drop: 200 MV

## FE16 SPECIFICATIONS

### DC VOLTS

Ranges: 0 to 1, 3, 10, 30, 100, 300 and 1000 FULL SCALE  
-.5 to .5, -1.5 to 1.5, -5 to 5, -15 to 15, -50 to 50, -150 to 150  
and -500 to 500 ZERO CENTER SCALE RANGES  
Input Resistance: 15 megohms shunted by 14 PF at jack or 37 PF thru cable  
Accuracy:  $\pm 1.5\%$   
AC Rejection: 30 to 300 times (30 to 50db).

### AC VOLTS

Ranges: (Rms)  
0 to 1, 3, 10, 30, 100, 300 and 1000 FULL SCALE  
Ranges: (Peak to Peak)  
0-2.8, 8.4, 28, 84, 280, 840 and 2800 Full scale, frequency  
compensated  
Input Resistance: 10 megohms shunted by 29 PF at jack or 118 PF thru cable  
Frequency Response: Flat: 25HZ to 1MHZ  
3db points: 10Hz to 10MHz  
Accuracy:  $\pm 3\%$

## OHMMETER

Ranges: 0 to 1000 ohms, 10K, 100K, 10 megohms and 1000 megohms  
Accuracy:  $\pm 2$  degrees ARC

## DC CURRENT MEASUREMENTS

Ranges: 0 - 100 microamps, 1ma, 10ma, 100ma and 1 Ampere  
Accuracy:  $+ 3\%$  full scale  
Internal Voltage Drop: 200MV

## GENERAL SPECIFICATIONS ON FE14 AND FE16

Meter: 4-1/2", 100 microamp  $\pm 2\%$ , diode protected and isolated from input  
Multiplier Resistors: 1% precision type on FE14; 1/2% on FE16  
Ohms Battery: 1.5V "C" cell, Eveready Type #1035 or equivalent  
Power supply battery: 9 volt, Eveready Type #222 or equivalent  
Weight (less Batteries): 3-1/4 lbs.  
Dimensions: 5" w x 7-3/16" h 3-1/16d  
Accessories: High Voltage probe (39A19) extends range to 30KV.

## CONTROLS ON THE FE14 & FE16

The Field Effect Meter is as simple to operate as a standard VOM. Panel controls include the RANGE switch, FUNCTION switch, meter ZERO ADJ, OHMS ADJ, and the off-on switch. The following is a brief description of each control and how it is used.

OFF-ON switch: The OFF-ON switch controls the power to the circuit in the Field Effect Meter. In the OFF position, the battery is disconnected from the circuit and the meter is off. In the ON position, the battery voltage is applied to the circuit and the meter is ready to go. A red flag appears in the switch opening to indicate when the Field Effect Meter is on. When measuring current, the OFF-ON switch may be left in the OFF position as no battery power is needed.

ZERO ADJ: The ZERO ADJ is used to position the pointer of the meter over the zero on the extreme left of the meter scale or to position the pointer on the center zero when using the zero center ranges of the Field Effect Meter.

OHMS ADJ: The OHMS ADJ is the same as that found on most meters. Prior to measuring resistance, the test leads are shorted together and the OHMS ADJ is rotated for a full scale deflection (zero ohms) as read on the ohms scale of the meter.

FUNCTION SWITCH: The FUNCTION switch selects the type of measurement to be preformed. Minus or Plus DC Volts or MA, AC volts or OHMS and the BATT. CHK.

RANGE SWITCH: The RANGE switch selects the desired range of current, voltage, or resistance to be measured.

#### SHIELDED LEAD ON THE FE16

The FE16 Field Effect Meter is equipped with a shielded lead on the positive input lead so that accurate AC measurements can be made in the presence of strong electrostatic and magnetic fields. The shield, which is also effective on high ohms ranges, is only connected when using the AC Volts/Ohms functions and is disconnected when making DC measurements to prevent capacitive loading of the circuit being measured.

Test lead connections to the FE16 are made through the red and black banana jacks. The shield connects through a small pin jack (plainly marked) so that it cannot be mistakenly used as one of the test lead connections.

#### OPERATING THE FE14 and FE16

The Sencore Field Effect Meters are simple and easy to operate. Set the Function switch to the desired test to be preformed, the RANGE switch to the desired range, connect the leads and read the results on the meter. Here is a brief description of how each test is performed.

READING DC VOLTS: To read DC volts, the Function switch is set to either plus or minus DCV/MA. The Range switch is set to the desired range of voltage from one volt to 1000 volts full scale. If the voltage to be measured is unknown, start with the highest range and work down until the voltage can be measured. Connect the leads to the circuit and read the results on the meter. When measuring voltage in RF-IF circuits, a 100K isolation resistor at the end of the red test lead will reduce capacitive effects without effecting accuracy of readings.

The DC voltage is read on the two black scales just above the mirror on the meter. The top DC scale is from zero to 1.0 volts and each mark is equal to .02 volts. The bottom scale is zero to 3.0 volts and each mark is equal to .1 volts. The zero to 1.0 scale is used for the 1, 10, 100, and 1000 volt ranges and the zero to 3.0 scale is used for the 3, 30, and 300 volt ranges. In use the meter indication is multiplied by 10, 100, or 1000 depending upon the range. For example, if the

range switch is on the 10 volt range and the meter reads .42 volts, the actual voltage is .42 times 10 or 4.2 volts DC.

**READING AC VOLTS:** To read AC volts, the Function switch is set to the ACV/OHMS position and the Range switch to the desired range. For RMS voltages the two black scales marked AC (RMS) are used. For peak to peak voltages, the two red scales directly below the AC (RMS) scales are used. The readings are multiplied in the same way as with the DC scales, to obtain the actual voltage present. On the zero to 1.0 AC (RMS) scale, each mark is .02 volts and on the zero to 3.0 volts scale, each mark is .1 volts. On the zero to 2.8 volts AC (P-P) scale, each mark is .1 volts and on the zero to 8.4 volts scale, each mark is .2 volts.

**READING DC VOLTS ZERO CENTER SCALE:** The zero center scales are used to read plus or minus voltages without the necessity of changing polarity with the leads or Function switch. To use the zero center scales, set the Function switch to plus DCV/MA position and adjust the ZERO ADJ until the meter reads at the zero mark in the center of the scale. This gives ranges of plus or minus .5 volts (top scale) or plus or minus 1.5 volts (bottom scale) times 10, 100, or 1000 depending upon the setting of the range switch. If the range switch is in the 300 volt position, the zero to 1.5 volts scale is used and becomes zero to 150 volts plus or minus. If the meter swings up scale or to the right, it is a positive voltage. If the meter swings down scale or to the left, it is a negative voltage. This unique feature allows you to determine the polarity as well as the amplitude of a DC voltage and is very handy in solid state servicing.

**READING OHMS:** To read resistance, set the Function switch to ACV/OHMS and the Range switch to the desired range of resistance to be read. After checking to see that the meter is "zeroed" at the left edge of the scale, short the leads together and adjust the OHMS ADJ control for full scale deflection of the meter. Unshort the leads and be sure that the meter returns to the extreme left of the scale. Place the unknown resistance between the two leads and read the resistance on the OHMS scale (top red scale on meter). Multiply the reading on the meter by the range used. For example, if the meter read 15 and the range switch was set on RX100, the actual resistance would be 15 times 100 or 1500 ohms. A slight oscillation of the meter pointer may appear due to AC pickup on the RX1 meg range. If this occurs, move to a better location to make measurements. On the FE16, this can be eliminated by plugging in the shield in the shield jack on the front panel.

**MEASURING DC CURRENT:** To measure DC current, the Function switch is set to either the plus or minus DCV/MA position and the Range switch to the desired range of current. The power to the Field Effect Meter does not have to be turned on and may be left off to conserve on battery life if you so desire. Connect the leads in series and read the resultant current on the meter. The 0 to 1.0 DC VOLTS (MA) scale is used on all current measurements. If the meter reads backwards, indicating that the leads are reversed, simply change the polarity with the Function switch to the opposite polarity and the meter will read up scale.

#### MEASURING HIGH VOLTAGE WITH THE FE14 AND FE16

**CAUTION:** High voltage is dangerous and caution should be observed when measuring high voltages. Be sure that the ground lead from the Field Effect Meter is connected to the ground on the unit. If the ground lead is not connected, you are merely extending the high voltage closer to you. Stand away from the unit you are measuring and keep one hand in your pocket as a safety measure. High voltage in color TV is especially dangerous because it can go as high as 30,000 volts and is regulated. If you should come across it, it will not load down.

The 39A19 High Voltage Probe is an optional accessory, used to extend the DC range of the Field Effect Meter to 30,000 volts. It contains a 1,485 megohm 2% resistor to give a 100X multiplier for any range of the Field Effect Meter. The special ranges of 3KV for boost voltages, 10KV for focus and 30KV for high voltage are marked right on the front panel. Do not measure voltages higher than 30KV with the 39A19 high voltage probe, as the maximum rating of the resistor is 30KV.

To use the High Voltage Probe, simply plug the test lead into the red jack of the Field Effect Meter and connect the black lead from the black jack to ground. Set the function switch to +DCV/MA (-DCV/MA if you are measuring a negative voltage) and the range switch to the 3KV, 10KV, or 30KV position depending upon the voltage to be measured.

To read the actual voltage, multiply the readings on the 3 volt scale by 1000 for the 3KV position, the 1 volt scale by 10,000 for the 10KV position, and the 3 volt scale by 10,000 for the 30KV position.

The High Voltage Probe can also be used to measure voltages of 100, 300, and 1000 volts DC with an input impedance of 1,500 megohms. To obtain this high input impedance, set the range switch to the 1, 3, or 10 volt range and measure the voltage using the 39A19 High Voltage Probe.

#### CHECKING THE BATTERIES OF THE FE14 AND FE16

The 9 volt transistor battery used in the Field Effect Meter can readily be checked using the BATT. CHK. position of the Function switch. The range switch may be in any position and will not effect the reading of the battery condition. If the meter reads in the green area or BATT GOOD section of the meter (lower right hand corner) the battery is good and the readings taken with the Field Effect Meter will be accurate. If the meter reads below the green area, the battery should be replaced. The ohms battery can also be checked easily by using the same scale on the Field Effect Meter. Set the switch to ACV-OHMS and the Range switch to Rx10. Adjust the meter for zero indication on the left edge of the scale with the ZERO ADJ control. Short the leads together and set the OHMS ADJ for full scale meter indication. Without unshorting the leads, switch the RANGE switch to RX1. If the meter reads in the green area or BATT GOOD (lower right hand corner) the ohms battery is good. If it reads below this, the ohms battery should be replaced.

#### MEASURING HIGH DC CURRENT

Up to 10 amps of DC current can be measured with the Field Effect Meter adaptor below. Use a double 3/4 inch banana plug and two feet of number 20 copper wire to form the shunt. The leads carrying the current to the shunt should be a number 14 or heavier with heavy clips to connect into the circuit.

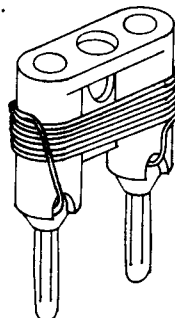

FIGURE 1

To use the 10 amp adaptor, plug it into the jacks on the Field Effect Meter. Set the range switch to the 100 microamp position and the Function switch to plus DCV/MA. The Field Effect Meter does not need to be turned on for current measurements. Multiply the readings on the 0 - 1 DC volts scale by 10 to get the current in amps. If the meter reads backwards, reverse the polarity by switching the minus DCV/MA position.

<u>Double 3/4" Banana plug Mfg.</u>	<u>Mfg. part number</u>
E. F. Johnson	Type 108
General Radio	274-MB
National	FWT
Pomona	MDP-AMDP-ST

### MEASURING AC CURRENT WITH THE FE14 AND FE16

The Field Effect Meter can be used to measure AC current with the circuit shown below. The resistor or resistors are placed in series with the AC source going to the device under test. The AC voltage drop across the resistor is measured and can be converted directly into AC amps. This adaptor may be built in a box with a switch to facilitate the switching. The resistors used are all one ohm of at least one watt. The Ohmite 995 series of 1 1/2 watt wirewound are ideal for this. A standard one watt carbon resistor will also work. If the unit is to be used for an extended period of time and is enclosed in a box, it is a good idea to use a two watt carbon in place of the one watt carbon resistor.

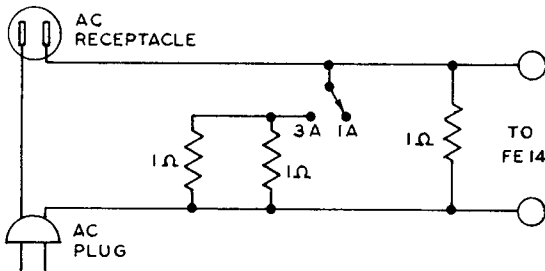

FIGURE 2

When measuring from zero to one amp, the one ohm resistor is used and the Function switch is set on ACV/OHMS and the Range switch to the one volt position. To measure three amps of AC current, three resistors are placed in parallel. The Range switch remains on the one volt range, but the three volt scale is read directly in amps. A 10 amp range can also be made by paralleling 10 one ohm resistors and using the one volt scale, multiply your readings by 10.

## MEASURING EXTREMELY SMALL CURRENTS WITH THE FE14 AND FE16

Very small currents nanoamps (.001 ua) may be measured using the Field Effect Meter in conjunction with a 3 volt battery.

Leakage currents of transistors and diodes and leakage currents through paper or electrolytic capacitors can be measured.

To make nanoamps measurements set the Function Switch to +DCV/ma and Range Switch to 3 volts. Connect the 3 volt battery across the input terminals; meter should read full scale or slightly higher. Connect transistor diode or capacitor between one battery terminal and the Field Effect Meter input. Observe polarity when connecting to device to obtain an accurate indication. Read current on ma scale and multiply reading by 200. Current measured will be in nanoamps. For example;

a germanium diode leakage indication is .98 ma.  $.98 \times 200 = 196$  nanoamps  
a silicon diode leakage indication is .1 ma.  $.1 \times 200 = 20$  nanoamps

## OVERLOAD PROTECTION ON THE FE14 AND FE16

The circuits and meter of the Field Effect Meters are protected from accidental overloads and application of excessive voltages. A silicon diode protects the transistors and circuit from damage. The meter is protected by two diodes and a resistor. The diodes shunt excessive current around the meter. If the current is excessively high or is applied for too long a period of time, the fuse resistor R24 will burn out protecting the meter and diodes. When this resistor is open, the current and ohms function of the Field Effect Meters will be inoperative, but the meter can still be used to measure voltage. R24 is a standard 100 ohm, 1/2 watt, 10% resistor, located on the Range switch, and is readily accessible when the meter is removed from the case.

## DISASSEMBLY INSTRUCTIONS

The Field Effect Meter does not have to be taken apart to replace the batteries. The door on the back of the Field Effect Meter gives access to the batteries and battery clips for ease of replacement. If the Field Effect Meter must be serviced or calibrated, the battery door must first be removed. Then the two screws holding the front panel to the case are removed. This allows the front panel to be lifted out for service. To separate the front panel from the case, the battery door with the batteries must be passed through the hole in the back of the case.

**BATTERY REPLACEMENT:** To replace the batteries in the Field Effect Meter, remove the screw holding the battery plate in the back of the instrument. The battery plate will slip out exposing the batteries in the clips on the plate.

The 9 volt battery can be replaced by any standard 9 volt transistor battery. An Eveready type #222 or equivalent is recommended as it will give longer battery life. The 1.5 volt "C" cell can be replaced by any standard "C" cell. One of the many long life types will provide longer life in use. To conserve on battery life, the Field Effect Meter should be turned off when not in use or when measuring current. The 9 volt battery is used only when the Field Effect Meter is measuring AC and DC volts and resistance.



## CALIBRATING THE FE14 AND FE16

The Field Effect Meter may be recalibrated easily and quickly if it becomes necessary by simply removing the battery plate. This will expose the controls on the printed board. Figure three shows the location of these controls. The 9 volt battery should be replaced with a fresh one if the Field Effect Meter is to be completely recalibrated. The DC BAL and the meter mechanical zero must be checked and readjusted if necessary before recalibrating the unit.

1. Set the front panel ZERO ADJ to the mechanical center of its rotation, the Range switch to the 1000 volt position, and turn the Field Effect Meter on.
2. With the Function switch in the plus DCV/MA position, adjust the DC BAL for a zero meter indication. Switch to minus DCV/MA. If the meter pointer moves, recheck and reset the meter mechanical zero with the Field Effect Meter turned off. Recheck the DC BAL for a zero meter indication.
3. Set the Range switch to the 1 volt position and the Function switch to ACV/OHMS. Apply a known 1 volt AC RMS voltage and adjust the AC CAL for full scale meter deflection. Remove your hand from the AC CAL pot to be sure you are not picking up any stray AC and adding it to the calibration of the Field Effect Meter. If an accurate source of AC is not available, the AC line may be used. In this case, set the Range switch to the 300 volt position and adjust the AC CAL control to read the line voltage. This will normally be 115 to 117 volts.

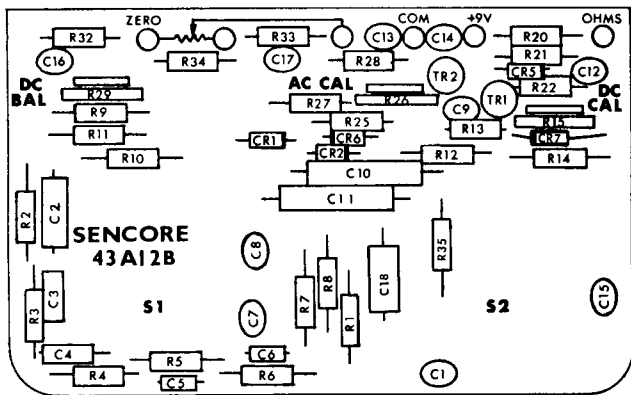

FIGURE 3

4. DC calibration is achieved by setting the Function switch to plus DCV/MA and the Range switch to the 1 volt position. Apply a known 1 volt DC source and adjust the DC CAL for a full scale deflection on the meter. A 1.5 volt battery may also be used to calibrate the Field Effect Meter. Set the Range switch to the 3 volt position and adjust the meter to indicate 1.55 volts which is the normal voltage from a new 1.5 volt battery. A more accurate calibration may be achieved with a mercury battery as its voltage is more constant and has closer tolerance.

## CIRCUIT DESCRIPTION:

The Sencore FE14 and FE16 Field Effect Meters uses a balanced differential amplifier with field effect transistors (FET) to provide the utmost in test meters - the flexibility and portability of a VOM with all the advantages of a VTVM, high input impedance, peak to peak AC etc.

Field effect transistors make this possible, because even though they are "solid state" they perform like a vacuum tube. The gate (grid) controls the current flow between the source (cathode) and drain (plate) by the effect of the electrostatic field between the gate and the source (bias). There isn't any gate current flow therefore the input impedance is extremely high. Since the FET does not have a cathode to "wear out" the Field Effect Meter is more stable and less subject to change than the conventional VTVM.

TR1 and TR2 (see schematic fig. 4) form the differential amplifier used for DC volts and Ohms measurements. With no voltage applied to the input of TR1, the ZERO ADJ control (R31) is set so that the voltages developed across source resistors R14 and R22 are equal, such that no current will flow thru the meter. The DC BAL control (R29) is an internal adjustment that performs the same as the ZERO ADJ control. It is used to compensate for component tolerances. When a DC voltage is applied to the input of TR1 the balance between TR1 and TR2 is upset and the meter will indicate in proportion to the voltage applied. Seven DC and AC ranges are provided with the input divider R1 thru R8. Capacitors C2 thru C8 compensate the divider for AC voltages. The DC CAL control (R15) is an internal adjustment used to calibrate the meter when a known DC voltage is applied to the input. When a very high voltage is applied to the gate of TR1 (Range switch set incorrectly) diode CR7 will conduct and keep the voltage applied to TR1 to a safe level to prevent destruction of the transistor.

Ohms measurements are made by forming a voltage divider with the unknown resistor and a known resistor - R9 for RX1 range, R10 for RX10 range etc. - and reading the voltage that is developed across the known resistor. Initially with the unknown resistor zero (leads shorted together) the OHMS ADJ control (R23) is set so that the meter reads at full scale with full potential from B1 applied to TR1. As external resistance is placed between the leads the meter will indicate proportionately lower. The meter is calibrated in ohms on the top scale.

For AC voltage measurements the AC voltage is applied to TR1 thru divider R2-R8 as with DC volts. The output of TR1 is fed to a peak to peak detector consisting of C10, C11, CR1 and CR2. The DC output is fed to TR2 thru divider R25, R26, R27 and CR6. The meter is in the source circuit of TR2. The DC voltage developed in the source of TR2, and consequently the meter indication is proportional to the peak to peak AC applied to TR1. Diodes CR5 and CR6 compensate for changes in temperature so that meter indications remain accurate over a wide temperature range.

DC current measurements are made using the meter and shunt resistors R16 thru R19. The transistors and associated circuitry are not used. On the 100 microamp range the meter is connected directly into the circuit.

Diodes CR3 and CR4 protect the meter movement from excessive overloads up to several amps. The diodes are protected with resistor R24 which will burn out when the maximum current rating of the diodes is exceeded. R24 is a standard 100 ohm 1/2 watt resistor.

## FIELD EFFECT METER TROUBLE CHART

<u>Symptom</u>	<u>Probable Cause</u>	<u>Corrective Measure</u>
Unit dead, meter does not read at all	Defective 9V battery (B2) Poor battery contact Broken red wire at ON OFF switch (S3) or at PC board Broken black wire from battery to PC board Defective Meter Shorted Diode CR3 or CR4	Replace battery Check battery contacts Check wiring to switch and to PC board Check black wire Replace Meter Replace defective diode
VOLTS measurements ok; but no indication on OHMS and MILLIAMPS functions	Burnt out fuse resistor R24	Replace R24, 100 ohms 1/2 w 10%
Cannot zero meter	Function and range switches in current positions. Poor contact at or/open resistor R32  Broken wire to zero adj control Transistors burnt out	Reset switches to correct positions  Resolder contact and change resistor if necessary Check wire to zero adj control. Replace transistors and recalibrate unit.
RX1 Function in Ohms measurement does not work.	Burnt out resistor R9	Replace resistor
RX10 Function in Ohms measurement does not work.	Burnt out resistor R10	Replace resistor
1 ma function only in current measurements does not work.	Burnt out resistor R16	Replace resistor
10 ma function only in current measurements does not work.	Burnt out resistor R17	Replace resistor
Cannot adjust Ohm zero to 0	Blue wire to ohms zero broken Poor contact at battery B1 Broken wire to battery contact Weak battery B1	Check for broken wire Check for poor contacts Check wiring  Replace with 1.5 volt "C" cell.

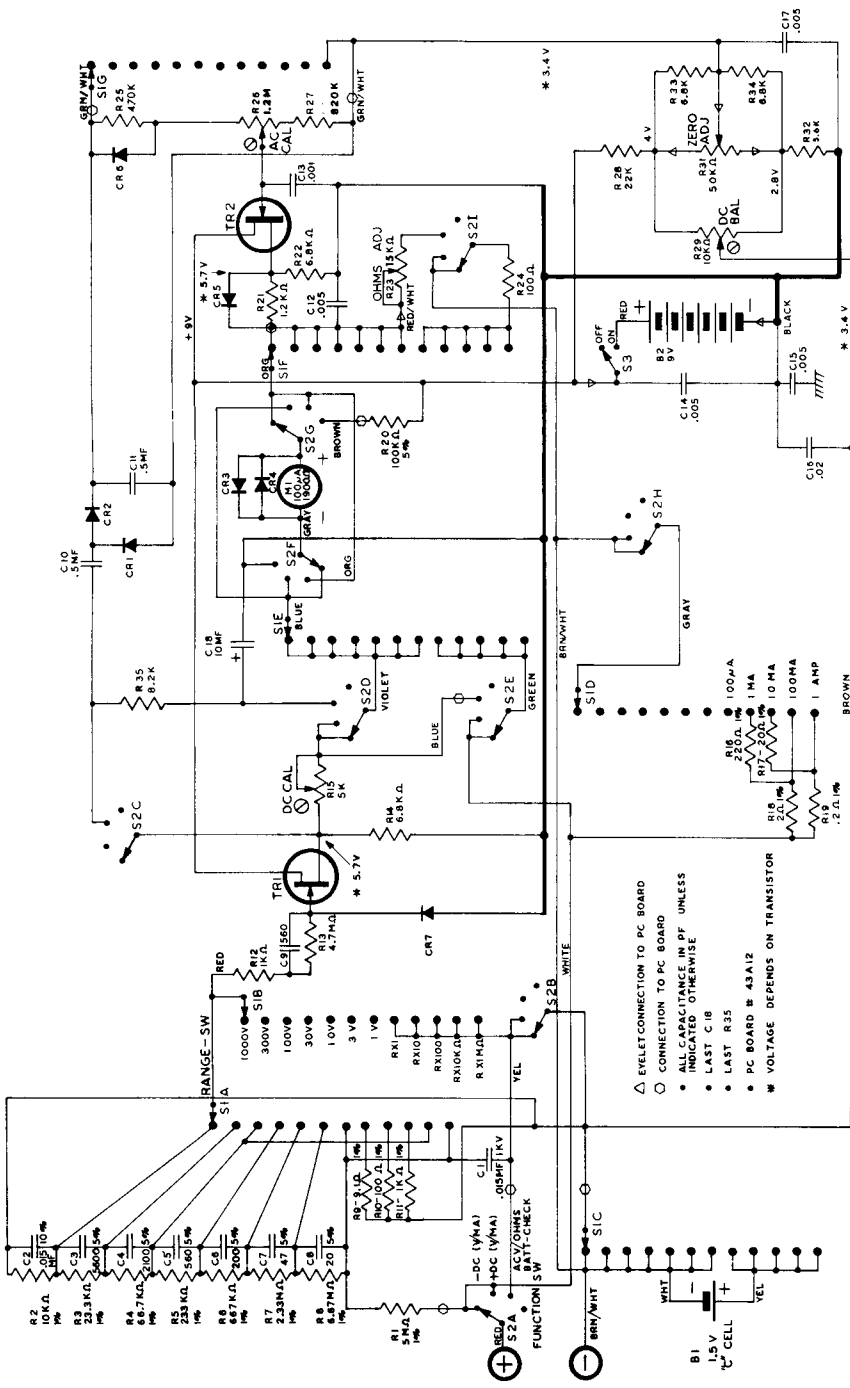

ISSUE DATE:

FE 14 SCHEMATIC

FE14 PARTS LIST

<u>REFERENCE NO.</u>	<u>PART NO.</u>	<u>DESCRIPTION</u>	<u>PRICE</u>
CR1, CR2, CR6	19G28A	Diode, Germanium	\$ .50
CR3, CR4	16G5	Diode rectifier .5A @400PIV	1.50
CR5	19G13	Diode, 1N34A	.50
CR7	50G2	Diode Silicon	.65
M1	23C25B	Meter 4 1/2", 100 microamp 1900 ohm coil	24.50
R1	14G271	5 meg 1/2W 1%	.75
R2	14G103	10K 1/2W 1%	.75
R3	14G266	23.3K 1/2W 1%	.75
R4	14G267	66.7K 1/2W 1%	.75
R5	14G268	233K 1/2W 1%	.75
R6	14G269	667K 1/2W 1%	.75
R7	14G270	2.33 meg 1/2W 1%	.75
R8	14G272	6.67 meg 1/2W 1%	.75
R9	14G264	9.1 ohm 1/2W 1%	.75
R10	14G265	100 ohm 1/2W 1%	.75
R11	14G101	1K 1/2W 1%	.75
R15	15G61	5K control PC Vert Mount	1.50
R16	14G275	220 ohm 1/2W 1%	.75
R17	14G274	20 ohm 1/2W 1%	.75
R18	14G273	2 ohm 1/2W 1%	.75
R19	14G143	8 1/4" Advance wire (.295 ohms ft)	.75
R23	15A75	15K control Tab mount 1" shaft	1.50
R26	15G66	1.2 meg control PC Vert Mount	1.95
R29	15A53	10K control PC Vert Mount	1.95
R31	15A68	50K control tab mount 1" shaft	1.95
TR1, TR2	19G27	Transistor SS3672 (FET)	1.50
C2	24G173	.015 mf 10% mylar	.25
C3	24G179	5600PF 5% N150	.25
C4	24G174	2100PF 5% N150	.25
C5, C9	24G141	560PF 5% N150	.25
C6	24G178	200PF 5% N150	.25
C18	24G120	10MF, 15 VOLTS	.35
S1	25A105	Range Switch 7P12P rotary	\$ 9.95
S2	25A104	Function Switch 8P4P rotary	8.95
S3	25G4	Slide Switch SPDT	.50
	10C215C	Case, vinyl clad steel	4.50
	10B216A	Panel, satin chrome screened	3.25
	10A222A	Battery plate (door)	.50
	33G143	Battery clip (1.5v "C" cell)	.50
	33G226	Battery clamp (9volt)	.50
	35G16	Battery plug 8" leads	.75

(PRICES SUBJECT TO CHANGE WITHOUT NOTICE)

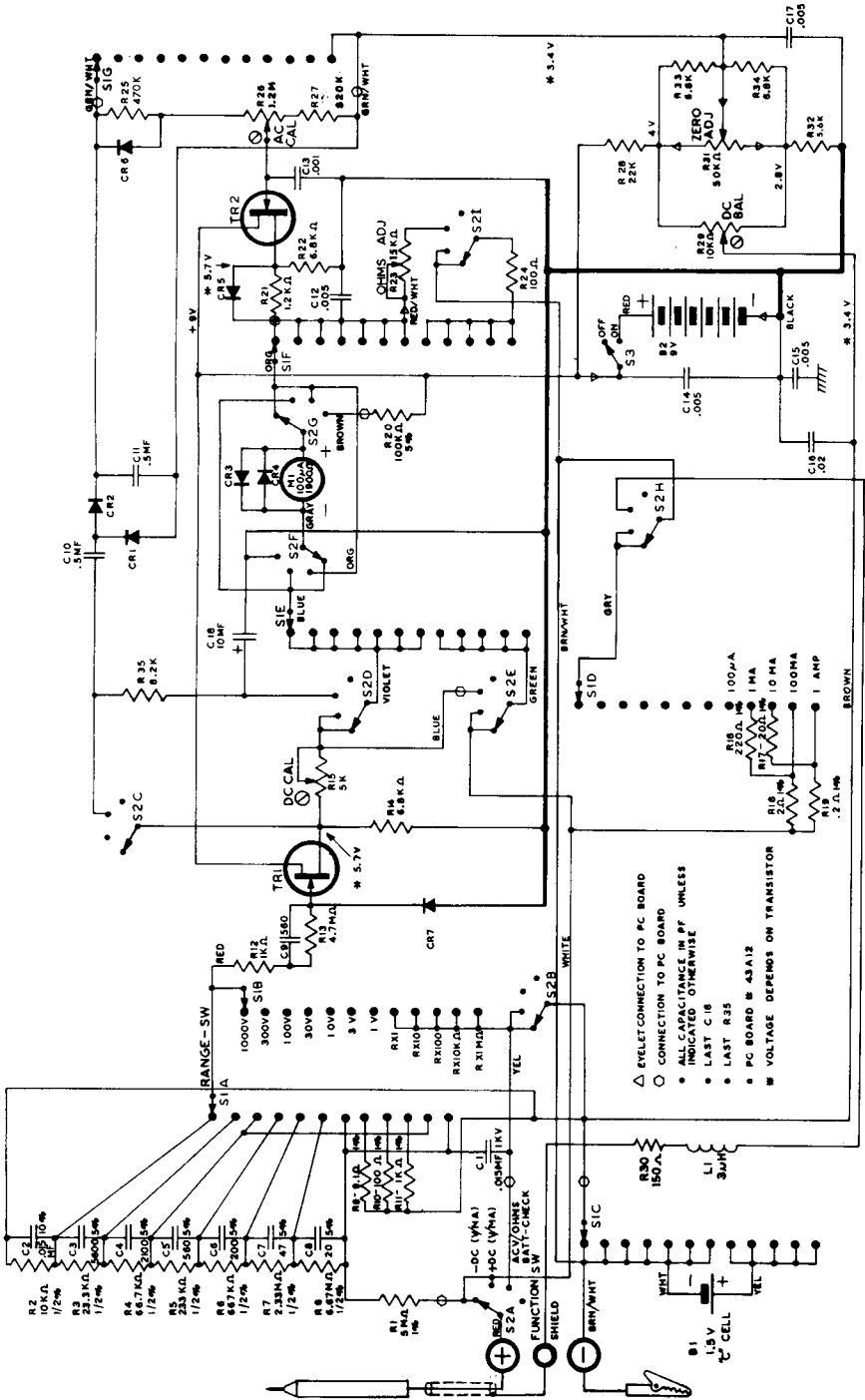

FE 16 SCHEMATIC

ISSUE DATE: 7-10-68

FE16 PARTS LIST

<u>REFERENCE NO.</u>	<u>PART NO.</u>	<u>DESCRIPTION</u>	<u>PRICE</u>
CR1, CR2, CR6	19G28A	Diode, Germanium	\$ .50
CR3, CR4	16G5	Diode rectifier .5A @400PIV	1.50
CR5	19G13	Diode, 1N34A	.50
CR7	50G2	Diode, Silicon	.65
M1	23C30	Meter 4 1/2", 100 microamp 1900 ohm coil	24.50
R1	14G271	5 meg 1/2W 1%	.75
R2	14G315	10K 1/2W 1/2%	1.25
R3	14G309	23.3K 1/2W 1/2%	1.25
R4	14G310	66.7K 1/2W 1/2%	1.25
R5	14G311	233K 1/2W 1/2%	1.25
R6	14G312	667K 1/2W 1/2%	1.25
R7	14G313	2.33 meg 1/2W 1/2%	1.25
R8	14G314	6.67 meg 1/2W 1/2%	1.25
R9	14G264	9.1 ohm 1/2W 1%	.75
R10	14G265	100 ohm 1/2W 1%	.75
R11	14G101	1K 1/2W 1%	.75
R15	15G61	5K control PC Vert Mount	.75
R16	14G275	220 ohm 1/2W 1%	.75
R17	14G274	20 ohm 1/2W 1%	.75
R18	14G273	2 ohm 1/2W 1%	.75
R19	14G143	8 1/4" Advance wire (.295 ohms ft)	.75
R23	15A75	15K control Tab mount 1" shaft	1.50
R26	15G66	1/2 meg control PC Vert Mount	1.95
R29	15A53	10K control PC Vert Mount	1.95
R31	15A68	50K control tab mount 1" shaft	1.95
TR1, TR2	19G27	Transistor SS3672 (FET)	1.50
C2	24G173	.015 mf 10% mylar	.25
C3	24G179	5600PF 5% N150	.25
C4	24G174	2100PF 5% N150	.25
C5, C9	24G141	560PF 5% N150	.25
C6	24G178	200PF 5% N150	.25
C18	24G120	10MF, 15 volts	.35
S1	25A105	Range Switch 7P12P rotary	9.95
S2	25A115	Function Switch 8P4P rotary	\$ 8.95
S3	25G4	Slide Switch SPDT	.50
	10C239	Case, vinyl clad steel	4.50
	10A222A	Battery plate (door)	.50
	33G143	Battery clip (1.5v "C" cell)	.50
	33G226	Battery clamp (9 volt)	.50
	35G16	Battery plug 8" leads	.75
	8B12	Panel sub, vinyl clad steel	3.00
	8A13	Panel, aluminum	3.00

(PRICES SUBJECT TO CHANGE WITHOUT NOTICE)

FE16 PARTS LIST

<u>REFERENCE NO.</u>	<u>PART NO.</u>	<u>DESCRIPTION</u>	<u>PRICE</u>
CR1, CR2, CR6	19G28A	Diode, Germanium	\$ .50
CR3, CR4	16G5	Diode rectifier .5A @400PIV	1.50
CR5	19G13	Diode, 1N34A	.50
CR7	50G2	Diode, Silicon	.65
M1	23C30	Meter 4 1/2", 100 microamp 1900 ohm coil	24.50
R1	14G271	5 meg 1/2W 1%	.75
R2	14G315	10K 1/2W 1/2%	1.25
R3	14G309	23.3K 1/2W 1/2%	1.25
R4	14G310	66.7K 1/2W 1/2%	1.25
R5	14G311	233K 1/2W 1/2%	1.25
R6	14G312	667K 1/2W 1/2%	1.25
R7	14G313	2.33 meg 1/2W 1/2%	1.25
R8	14G314	6.67 meg 1/2W 1/2%	1.25
R9	14G264	9.1 ohm 1/2W 1%	.75
R10	14G265	100 ohm 1/2W 1%	.75
R11	14G101	1K 1/2W 1%	.75
R15	15G61	5K control PC Vert Mount	.75
R16	14G275	220 ohm 1/2W 1%	.75
R17	14G274	20 ohm 1/2W 1%	.75
R18	14G273	2 ohm 1/2W 1%	.75
R19	14G143	8 1/4" Advance wire (.295 ohms ft)	.75
R23	15A75	15K control Tab mount 1" shaft	1.50
R26	15G66	1/2 meg control PC Vert Mount	1.95
R29	15A53	10K control PC Vert Mount	1.95
R31	15A68	50K control tab mount 1" shaft	1.95
TR1, TR2	19G27	Transistor SS3672 (FET)	1.50
C2	24G173	.015 mf 10% mylar	.25
C3	24G179	5600PF 5% N150	.25
C4	24G174	2100PF 5% N150	.25
C5, C9	24G141	560PF 5% N150	.25
C6	24G178	200PF 5% N150	.25
C18	24G120	10MF, 15 volts	.35
S1	25A105	Range Switch 7P12P rotary	9.95
S2	25A115	Function Switch 8P4P rotary	\$ 8.95
S3	25G4	Slide Switch SPDT	.50
	10C239	Case, vinyl clad steel	4.50
	10A222A	Battery plate (door)	.50
	33G143	Battery clip (1.5v "C" cell)	.50
	33G226	Battery clamp (9 volt)	.50
	35G16	Battery plug 8" leads	.75
	8B12	Panel sub, vinyl clad steel	3.00
	8A13	Panel, aluminum	3.00

(PRICES SUBJECT TO CHANGE WITHOUT NOTICE)



1035.99  
}

1035.99  
2  
3  
4  
5  
6  
7  
8  
9  
10  
11  
12  
13  
14  
15  
16  
17  
18  
19  
20  
21  
22  
23  
24  
25  
26  
27  
28  
29  
30  
31  
32  
33  
34  
35  
36  
37  
38  
39  
40  
41  
42  
43  
44  
45  
46  
47  
48  
49  
50  
51  
52  
53  
54  
55  
56  
57  
58  
59  
60  
61  
62  
63  
64  
65  
66  
67  
68  
69  
70  
71  
72  
73  
74  
75  
76  
77  
78  
79  
80  
81  
82  
83  
84  
85  
86  
87  
88  
89  
90  
91  
92  
93  
94  
95  
96  
97  
98  
99  
100



**SENCORE, INC.**

426 S. WESTGATE DRIVE, ADDISON, ILLINOIS