

# INSTRUCTIONS FOR INSTALLING AND OPERATING PHILCO 41-95

*A Musical Instrument of Quality*

## BATTERY OPERATED RADIO FOR STANDARD BROADCAST RECEPTION

Philco Model 41-95 is a five tube battery operated superheterodyne radio. It operates from a plug-in-type "A" and "B" Pack.

The Philco High Efficiency Tubes used in this model are: 1-1A7G, 1st Detector and Oscillator; 1-1N5G, I. F. Amplifier; 1-1H5G, 2nd Detector, A. F. Amplifier and Automatic Volume Control; and 2-1A5G, Push Pull Output.

### INSTALLATION

After unpacking the radio make sure all the tubes are in their correct sockets, pressed firmly down, with the grid clips in place. A label inside the cabinet will show the relative location of the tubes.

TO INSURE THE BEST POSSIBLE RECEPTION, ON THE COMPLETE TUNING RANGE OF THIS RECEIVER, THE "PHILCO FARM RADIO AERIAL" MUST BE USED. This Aerial (Part No. 40-6383) complete with instructions for installing, may be obtained from your Philco Dealer. Make the aerial connection to the receiver by twisting the bare end of the lead-in wire tightly around the bare end of the white wire at the rear of the chassis.

A GOOD GROUND CONNECTION IS ABSOLUTELY NECESSARY WITH THIS RADIO. Make the connection from the black wire at the rear of the chassis to the nearest water or radiator pipe. If there is no ground convenient, construct one by driving a four foot length of metal into moist earth.

The Philco Model 41-95 requires one Philco plug-in type "A" and "B" pack (Part No. P-60D11L). This battery may be obtained from your Philco Dealer.

Remove the wood strip from the rear of the cabinet and insert the battery in the space provided for it at the rear of the chassis. In the floor-type cabinet, it may be placed in the bottom of the cabinet.

Insert battery cable plug into the battery, observing the arrangement of the pins on the plug and the corresponding holes in the socket of the battery so as to be sure of inserting it correctly. Replace the wood strip to hold battery firmly in place.

### OPERATION

#### On-Off Switch and Volume Control

Turn the left hand knob clockwise until a click is heard and the on-off indicator on the dial shows red. Further rotation will increase the volume.

#### Station Selector

To tune a station, turn the "On-Off Switch and Volume Control" knob to about half its total range, and select the station by rotating the right hand, "Station Selector", knob.

For best tone, tune the desired station with the volume control low. This enables you to get the exact point where the station comes in best. Then adjust the volume to desired level with the volume control. DO NOT reduce the volume by tuning away from the station.

Some Police Stations may be tuned in above 1600 KC.

### BATTERY LIFE

The life of the battery will depend upon how often and how long the receiver is used. With average use of several hours per day a reasonable life should be obtained. If reception becomes weak after several months, have the voltage of the battery checked.

### SERVICE

For the convenience of all radio owners, Philco has developed a plan for prompt, efficient radio service in every locality. This plan is known as "Radio Manufacturers Service". There is a member in your neighborhood — his shop or store can be identified by the emblem shown here. To make sure of guaranteed work, genuine Philco tubes and parts, and standard prices — call a member of "Radio Manufacturers Service".



INSTRUCTIONS FOR INSTALLING AND OPERATING MODEL 41-95

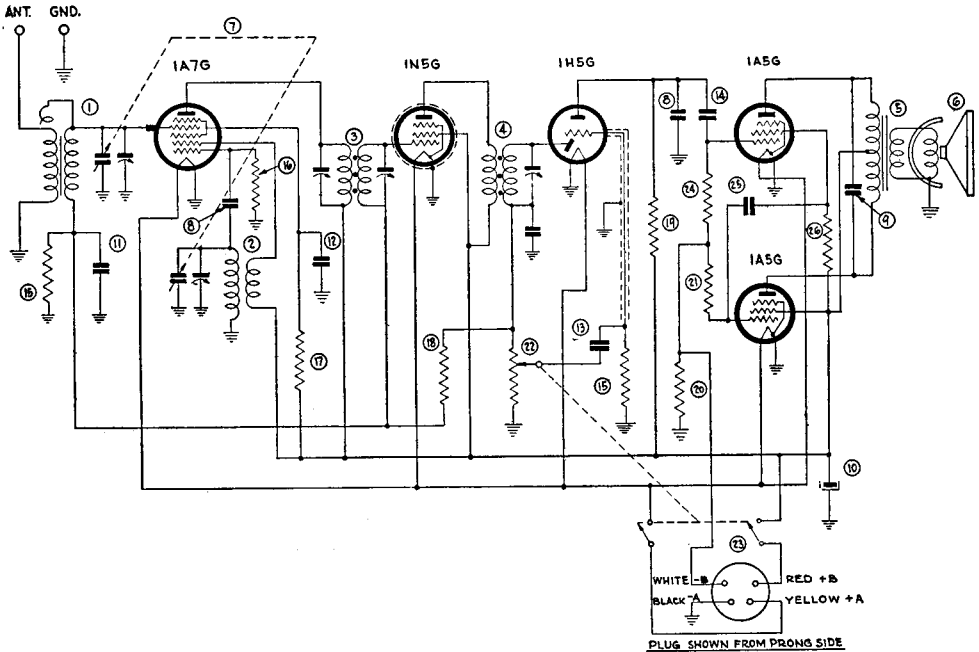

REPLACEMENT PARTS — PHILCO 41-95

Schem. No.	Description	Philco Part No.	Schem. No.	Description	Philco Part No.
1	Antenna Transformer	32-3183	14	Tubular Condenser (.01 mf., 400 v)	30-4572
2	Oscillator Transformer	32-3184	15	Resistor (4.7 Meg., ¼ watt)	33-547154
3	1st I. F. Transformer	32-3198	16	Resistor (220,000 ohms, ¼ watt)	33-422154
4	2nd I. F. Transformer	32-3199	17	Resistor (68,000 ohms, ¼ watt)	33-368154
5	Output Transformer	32-8107	18	Resistor (10 Meg., ¼ watt)	33-610154
6	5" Speaker for Compact	36-1507	19	Resistor (1 Meg., ¼ watt)	33-510154
6A	8" Speaker for Console	36-1477	20	Resistor (680 ohms, ½ watt)	33-168326
7	Tuning Condenser	31-2457	21	Resistor (2.2 Meg., ¼ watt)	33-522154
8	Moulded Mica Condenser (100 mmf.)	60-110157	22	Volume Control (1 Meg. with DPST switch)	33-5398
9	Moulded Mica Condenser (250 mmf.)	60-125157	23	Battery Cable	41-3505
10	Electrolytic Condenser (10 mf., 150 v)	30-2396	24	Resistor (2.2 Meg., ¼ watt)	33-522154
11	Tubular Condenser (.05 mf., 200 v)	30-4519	25	Tubular Condenser (.01 mf., 400 v)	30-4572
12	Tubular Condenser (.05 mf., 200 v)	30-4444	26	Resistor (10,000 ohms, ¼ watt)	33-310154
13	Tubular Condenser (.004 mf., 400 v)	30-4578			

WARRANTY

We warrant each new Philco Radio Receiver and Speaker to be free from defects in material and workmanship under normal use and service, our obligation under this warranty being limited to making good at our depot any part or parts thereof which shall, within ninety (90) days after delivery of such Receiver to the original retail purchaser, be returned to our depot with transportation charges prepaid, and which our examination shall disclose to our satisfaction to have been thus defective; this warranty being expressly in lieu of all other warranties expressed or implied, and of all other obligations or liabilities on our part, and we neither assume nor authorize any representative or other person to assume for us any other liability in connection with the sale of Receivers or Speakers.

This warranty shall not apply to any Receiver or Speaker which shall have been repaired or altered other than by us in any way so as, in our judgment, to affect its stability or reliability, nor which has been subject to misuse, negligence or accident, nor which has had the serial number altered, effaced or removed. Neither shall this warranty apply to any Receiver or Speaker which has been connected therewith than in accordance with the instructions furnished by us.